

Functional Tests

Agilent Technologies N9010A EXA Signal Analyzer



Agilent Technologies

Manufacturing Part Number: N9010-90005

Printed in USA

August 2007

© Copyright 2006 - 2007 Agilent Technologies, Inc.

Notice

The information contained in this document is subject to change without notice.

Agilent Technologies makes no warranty of any kind with regard to this material, including but not limited to, the implied warranties of merchantability and fitness for a particular purpose. Agilent Technologies shall not be liable for errors contained herein or for incidental or consequential damages in connection with the furnishing, performance, or use of this material.

Where to Find the Latest Information

Documentation is updated periodically. For the latest information about Agilent EXA signal analyzer, including software updates and application information, please visit the following Internet URLs:

<http://www.agilent.com/find/exa>

1. Functional Tests	
Functional Test Versus Performance Verification	6
Contents of this Document	7
Before Performing a Functional Test	8
Test Equipment	9
2. Displayed Average Noise Level (DANL)	
Procedure	14
3. Frequency Readout Accuracy	
Procedure	18
4. Amplitude Accuracy at 50 MHz	
Procedure	21
Testing Preamp Option (P03)	23
Procedure	23
5. Frequency Response (Flatness)	
Procedure	27
6. Frequency Response (Flatness), Preamp On	
Procedure	31
7. Scale Fidelity	
Procedure	35

Contents

1 Functional Tests

Functional tests are tests of various instrument parameters that give a high degree of confidence that the analyzer is operating correctly. They are recommended as a check of analyzer operation for incoming inspection or after a repair. Measurement uncertainty analysis is not available for functional tests, and the analyzer is checked against limits that are wider than the published specifications. The functional tests are designed to test an analyzer operating within the temperature range defined by the analyzer specifications using a minimum set of test equipment. If a test does not pass, performance verification tests must be run to determine whether a problem exists.

Functional Test Versus Performance Verification

Functional tests use a minimum set of test equipment to check a much smaller range of parameters (and a limited number of data points for each parameter) than do performance verification tests. Functional tests use limits that are wider than the published specifications; measurement uncertainty analysis is *not* available for functional tests.

NOTE If a functional test does not pass, you must run performance verification tests to determine whether a problem exists.

Performance verification tests span a wide range of instrument parameters and provide the highest level of confidence that the instrument conforms to published specifications. These tests can be time consuming and require extensive test equipment.

Contents of this Document

This chapter includes the following:

- “Before Performing a Functional Test” on page 8 (what to do first).
- “Test Equipment” on page 9 (a list of the equipment required for *all* of the tests).

Subsequent chapters describe the following Functional Tests:

- “Displayed Average Noise Level (DANL)” on page 13
- “Frequency Readout Accuracy” on page 17
- “Second Harmonic Distortion (SHD)” on page 19
- “Amplitude Accuracy at 50 MHz” on page 19
- “Amplitude Accuracy at 50 MHz” on page 19
- “Frequency Response (Flatness)” on page 25
- “Frequency Response (Flatness), Preamp On” on page 29
- “Scale Fidelity” on page 33

Each functional test includes:

- Test limits (pass/fail criteria)
- A description of the test
- The equipment required for the test
- A figure showing how to connect the equipment
- Step-by-step instructions
- One or more tables in which to record the measurement results

Before Performing a Functional Test

1. Ensure that you have the proper test equipment.
2. Switch on the unit under test (UUT) and let it warm up (in accordance with warm-up requirements in the instrument specifications).
3. Allow sufficient warm-up time for the required test equipment (refer to individual instrument documentation for warm-up specifications).
4. Ensure that the analyzer's frequency reference is set to Internal:
 - a. Press the **Input/Output**, **More**, **Freq Ref In** keys.
 - b. If the **Freq Ref In** softkey does *not* show **Internal**, press the **Freq Ref In** softkey and select **Internal**.
5. Following instrument warm-up, perform the auto align routine:
Press **System**, **Alignments**, **Align Now**, **All**.

NOTE Functional test accuracy depends on the precision of the test equipment used. Ensure that all of the test equipment is calibrated before running a functional test.

TEST EQUIPMENT

The table below summarizes the test equipment needed to perform all of the functional tests. Alternate equipment model numbers are given in case the recommended equipment is not available. If neither the recommended nor the alternative test equipment are available, substitute equipment that meets or exceeds the critical specifications listed.

Analyzer Option	Item	Critical Specifications	Recommended Agilent Model	Alternate Agilent Model
Adapters				
All	3.5 mm (f) to 3.5mm (f) (connector saver for source)	Frequency: 10 MHz to 26.5 GHz VSWR: < 1.1:1	83059B	1250-1749
All	BNC (f) to SMA (m)	Frequency: 40 MHz	1250-1200	
All	Type N (f) to Type N (f)	Frequency: 10 MHz to 18 GHz VSWR: < 1.05:1	1250-1472	1250-0777
All	Type N (m) to 3.5 mm (m)	Frequency: 10 MHz to 18 GHz VSWR: < 1.1:1	1250-1743	
All	Type N (m) to 3.5 mm (f)	Frequency: 10 MHz to 18 GHz VSWR: < 1.1:1	1250-1744	
All	Type N (f) to 3.5 mm (f)	Frequency: 10 MHz to 18 GHz VSWR: < 1.1:1	1250-1745	
All	Type N (m) to BNC (f)	Frequency: 10 MHz to 1 GHz VSWR: < 1.05:1	1250-1476	
Attenuators				
All	10 dB Step Attenuator	Frequency: 50 MHz Range: 0 to 70 dB	8495A	8496A
All	10 dB Fixed Attenuator (2 required)	Frequency: 50 MHz VSWR: < 1.2:1	8493C Option 010	8493A Option 010 or 8493B Option 010
Pxx	30 dB Fixed Attenuator	Accuracy: < 0.05 dB @ 50 MHz	11708A	
Cables				
All	3.5 mm (1 meter)	Frequency: 10 MHz to 26.5 GHz VSWR: < 1.4:1 Loss: < 2.0 dB	11500E	8120-4921

Functional Tests
Test Equipment

Analyzer Option	Item	Critical Specifications	Recommended Agilent Model	Alternate Agilent Model
All	Cable, BNC (3 required)	120 cm (48 in.) BNC cable	10503A	
Signal Source				
All	Synthesized Sweeper	<i>Frequency: 10 MHz to 26.5 GHz</i> <i>Harmonic level: < -40 dBc</i> <i>Amplitude range: 10 to -20 dBm</i> <i>Frequency Accuracy: 0.02%</i>	PSG ^a	83630B, 83640B, 83650B
Power Meter				
All	Power Meter	<i>Power Reference Accuracy: ±1.2%</i> Compatible with power sensor	E4418B	E4419B
All	Power Sensor	<i>Frequency Range: 50 MHz to 3.66 GHz</i> <i>Amplitude Range: -70 to -10 dBm</i>	8481D	8487D 8485D
P03	Low Power Sensor	<i>Frequency Range: 50 MHz to 3.6 GHz</i> <i>Amplitude Range: -70 to -10 dBm</i>	8481D	8485D 8487D
Pxx other than P03	Low Power Sensor	<i>Frequency Range: 50 MHz to 26.5 GHz</i> <i>Amplitude Range: -70 to -10 dBm</i>	8485D	8487D
Oscilloscope				
All	Agilent Infiniium Oscilloscope	<i>Cutoff Frequency: 50 MHz</i> <i>Rejection at 65 MHz: > 40 dB</i> <i>Rejection at 75 MHz: > 60 dB</i> <i>Rejection at 80 MHz: > 60 dB</i> <i>Frequency: 10 MHz to 26.5 GHz</i>	54800B	
Miscellaneous Equipment				
All	Filter, 50 MHz Low Pass	<i>Cutoff Frequency: 50 MHz</i> <i>Rejection at 65 MHz: > 40 dB</i> <i>Rejection at 75 MHz: > 60 dB</i> <i>Rejection at 80 MHz: > 60 dB</i> <i>Frequency: 10 MHz to 26.5 GHz</i>	0955-0306	
526	Power Splitter, 3.5 mm	<i>Nominal Insertion Loss: 6 dB</i> <i>Tracking Between Ports: < 0.25 dB</i>	11667B	
503, 507, 513	Power Splitter	<i>Nominal Insertion Loss: 6 dB</i> <i>Tracking Between Ports: < 0.25 dB</i>	11667A	11667B

Analyzer Option	Item	Critical Specifications	Recommended Agilent Model	Alternate Agilent Model
All	Termination, 50Ω	Type N (m) Connector <i>Frequency: 30 Hz to 26.5 GHz</i>	909A Option 012	

- a. PSG model numbers: E8244A, E8254A, E8247C Option 520, E8247C Option H31 or 540, E8257D Option 520, E8257D Option 550, E8257D Option 567, E8267D Option 544.

2 Displayed Average Noise Level (DANL)

Test Limits (with 0 dB input attenuation)

See [Table 2-1](#) for values.

The Displayed Average Noise Level (DANL) of the signal analyzer is measured across a 10 kHz frequency span at several center frequencies. The analyzer input is terminated into a 50Ω load. A test is performed to assure the measurement is not performed in the presence of a residual response. The measurement is then averaged, and the result is normalized to a 1 Hz bandwidth.

Item	Critical Specifications (for this test)	Recommended Agilent Model
Termination, 50Ω Type-N(m)	<i>Frequency: DC to 18 GHz</i>	909A Option 012

Figure 2-1. DANL Test Setup

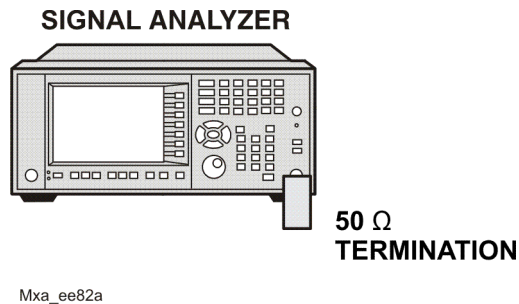

Procedure

1. Configure the equipment as shown in [Figure 2-1](#).
2. Press **Mode, Spectrum Analyzer, Mode Preset** on the analyzer.
3. Set up the signal analyzer by pressing:
 - FREQ Channel, Center Freq, 10, MHz**
 - Input/Output, RF Input, RF Coupling, select DC**
 - SPAN X Scale, Span, 10, kHz**
 - AMPTD Y Scale, -70, dBm**
 - AMPTD Y Scale, Attenuation, Mech Atten, 0, dB**
 - BW, Res BW, 1, kHz**
 - BW, Video BW, 100, Hz**
 - Meas Setup, Average/Hold, Number, 20, Enter**
 - Trace/Detector, Trace Average**
 - Single**
4. Press **Restart**, then wait for Average/Hold to display 20/20.
5. Press **View/Display, Display**, then press **Display Line, On**.
6. Rotate the knob and set the display line at the average amplitude of the displayed noise floor by visual inspection.
7. Confirm that the measurement is performed on the analyzer noise floor and not on a residual response within the displayed 10 kHz span.

NOTE Ignore the residual response if one appears when taking the measurement.

8. Enter the value of the display line as the Measured Average Noise Level at 10 MHz column in [Table 2-1](#).
9. Normalize the measured value to a 1 Hz BW by adding -30 dB to the measured value.

NOTE The -30 dB value is added because the formula used to calculate the value of the noise power in a 1 Hz BW when measured with a 1 kHz BW is:

Normalized Noise = $10 \text{ Log (BW 2/BW 1)}$ where BW 2 is the 1 kHz BW we measure and BW 1 is 1 Hz BW to which we want to normalize.

Therefore, $10 \text{ Log (1000)} = 30 \text{ dB}$, so the noise floor will be 30 dB lower in a 1 Hz BW.

10. Enter the normalized value of the displayed average noise level in [Table 2-1](#).
11. The value of the normalized displayed average noise should be less than the specification value.
12. Change the analyzer center frequency to the next value listed in [Table 2-1](#). Press:

FREQ Channel, Center Freq, [Table 2-1 Value], GHz

13.Repeat [step 7](#) through [step 12](#) to fill in the remainder of [Table 2-1](#) for your analyzer frequency range.

Table 2-1 Displayed Average Noise Level (DANL) Results

Center Frequency	Measured Average Noise Level (dBm)	Normalized Average Noise Level/(1 Hz BW) (dBm)	Test Limits (dBm)
10 MHz			-145
2 GHz			-145
6 GHz			-143
13 GHz			-142
20 GHz			-136
26.5 GHz			-133

Displayed Average Noise Level (DANL)
Procedure

3 Frequency Readout Accuracy

Test Limits

Frequency Readout Accuracy is equivalent to the following equation:

$$\pm(0.25\% \times \text{span} + 5\% \times \text{RBW} + 2 \text{ Hz} + 0.5 \times \text{horizontal resolution})$$

See results table for actual values.

The frequency readout accuracy is measured in several spans and center frequencies that allow both internal analyzer synthesizer modes and prefilter bandwidths to be tested. Frequency reference error is eliminated by using the same frequency standard for the analyzer and signal source.

Item	Critical Specification (for this test)	Recommended Agilent Model
Adapter, Type-N(m), to 3.5 mm(f)	Frequency: 10 MHz to 1.51 GHz VSWR: < 1.1:1	1250-1744
Adapter, 3.5 mm(f) to 3.5 mm(f)	Frequency: 10 MHz to 1.51 GHz VSWR: < 1.1:1	83059B
Cable, 3.5 mm, 1 meter	Frequency: 10 MHz to 1.51 GHz VSWR: < 1.4:1	11500E
Cable, BNC, 120 cm	Frequency: 10 MHz	10503A
Synthesized Sweeper	Frequency: 10 MHz to 1.51 GHz	PSG

Figure 3-1 Frequency Readout Accuracy Test Setup

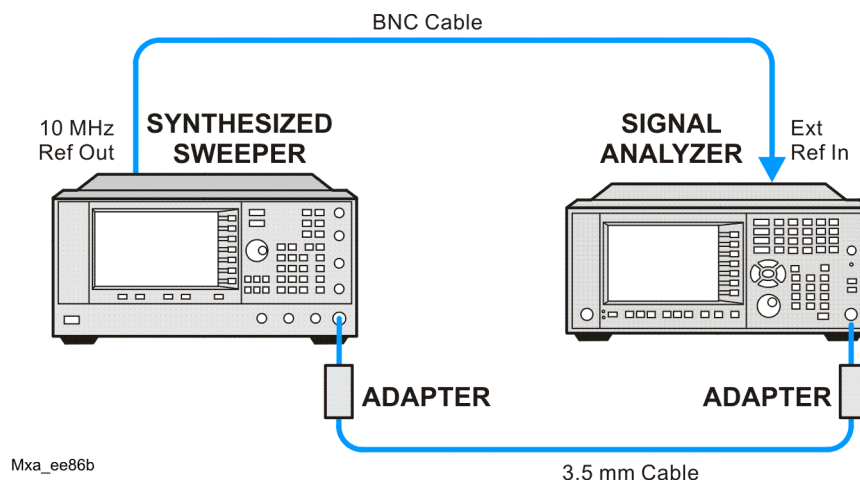

Procedure

1. Configure the equipment as shown in [Figure 3-1](#). Confirm the analyzer's built-in auto alignment has been performed within the past 24 hours.
2. On the synthesized sweeper, press **PRESET**, then set the controls as follows:

FREQUENCY, 1505, MHz
POWER LEVEL, -10, dBm

3. Set up the signal analyzer by pressing:

Mode, Spectrum Analyzer
Mode Preset
Input/Output, More, Freq Ref In, External
FREQ Channel, Center Freq, 1505, MHz
SPAN X Scale, Span, 2990, MHz
Trace/Detector, More, Detector, Sample
Single

4. Press **Restart**.

Press **Peak Search** on the analyzer. If the instrument is functioning correctly, the marker reading in the active function block will be between the values listed in [Table 3-1](#). Record the marker value in the Marker Frequency Readout column in [Table 3-1](#).

5. On the signal analyzer, change the span and center frequency as listed in [Table 3-1](#).
6. Change the synthesized sweeper frequency to match the center frequency of the analyzer.
7. Repeat [step 4](#) through [step 6](#) until the Marker Frequency Readout column of [Table 3-1](#) is complete.

Table 3-1 Frequency Readout Accuracy Results

Span (MHz)	Center Frequency (MHz)	Minimum	Marker Frequency Readout	Maximum
2990	1505	1495.9 MHz		1514.1 MHz
127.2	1505	1504.56 MHz		1505.44 MHz
54.1	1505	1504.8122 MHz		1505.1878 MHz
7.95	1505	1504.97240 MHz		1505.0276 MHz
0.106	1505	1504.999630 MHz		1505.000370 MHz
1.98	517.59	517.58316 MHz		517.59684 MHz
1.98	832.50	832.49316 MHz		832.50684 MHz

4 Amplitude Accuracy at 50 MHz

Test Limits

Amplitude Accuracy should remain within ± 1.20 dB of the measured source value across the range of source levels and changes in resolution bandwidth. The Preamp (option P03) should remain within ± 1.3 dB of measured values.

A synthesized sweeper is used as the signal source for the test. The source amplitude is varied using the signal source amplitude control and external step attenuator. The resolution bandwidth is also varied on the signal analyzer. The source amplitude is measured by the power meter and signal analyzer at each setting, and the values compared. The difference between each pair of measurements indicates the amplitude accuracy.

Item	Critical Specifications	Recommended Agilent Model
Adapter	Type-N(m), to 3.5 mm(m)	1250-1743
Adapter	3.5 mm(f) to 3.5 mm(f)	83059B
Attenuator, 10 dB Step	<i>Range: 10 to 30 dB</i> <i>Frequency: 50 MHz</i> <i>Accuracy: ± 0.5 dB</i>	8495A
Attenuator, 30 dB	<i>Accuracy: < 0.5 dB at 50 MHz</i>	11708A
Cable	3.5 mm, 1 meter	11500E
Cable	BNC, 120 cm	10503A
Power Meter	Compatible with power sensor	E4418B
Power Sensor	<i>Amplitude Range: -25 dBm to 10 dBm</i>	8485A
Power Splitter	3.5 mm (f) connectors 6 dB loss	11667B
Synthesized Sweeper	<i>Typical Temperature Stability: 0.01 dB/$^{\circ}$C</i>	PSG

Figure 4-1. Amplitude Accuracy Test Setup

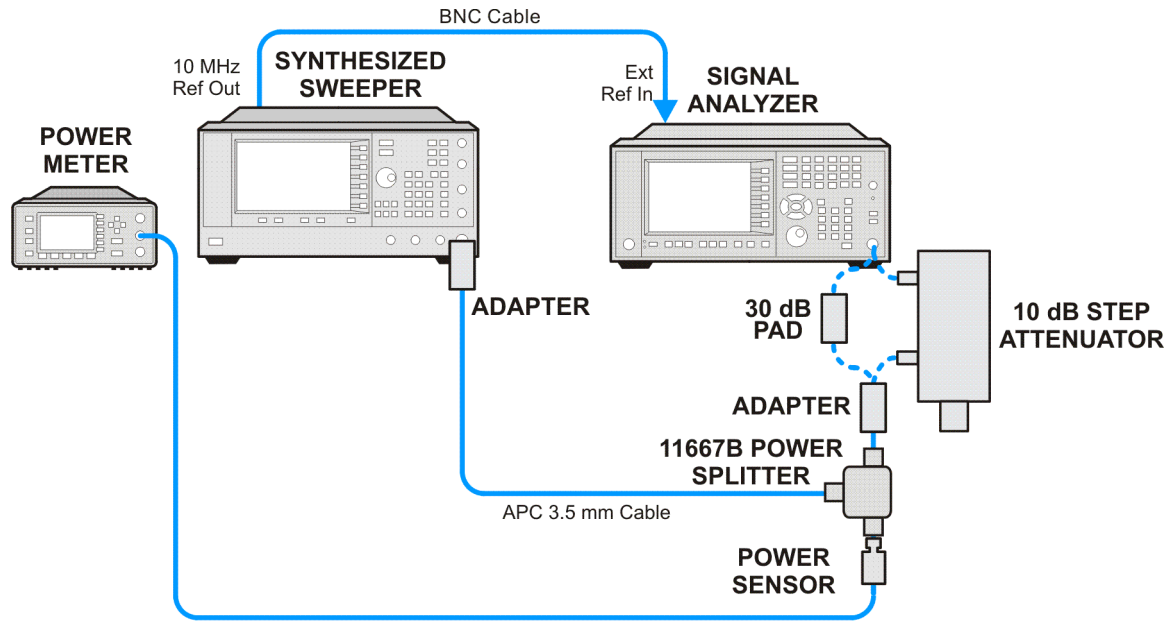

Mxa_ee181a

Procedure

1. Zero and calibrate the power meter.
2. Configure equipment as shown in [Figure 4-1.](#), with the power splitter connected directly to the signal analyzer input through the step attenuator and adapter.

CAUTION To minimize stress on the test equipment connections, support the power sensor.

3. If the auto alignment for the analyzer has not been performed within the past 24 hours, press **System, Alignments, Align Now, All** to perform the auto alignment routine.
4. Press **Mode, Spectrum Analyzer, Mode Preset** on the analyzer.
5. Set up the synthesized sweeper by pressing:

CW, 50, MHz
Power Level, -4, dBm
RF (On)

6. Set up the signal analyzer by pressing:

Input/Output, More, Freq Ref In, External
FREQ Channel, Center Freq, 50, MHz
SPAN X Scale, 2, MHz
AMPTD Y Scale, Attenuation, Mech Atten, 10, dB
Input/Output, RF Input, RF Coupling, select DC
Sweep/Control, Sweep Setup, Swp Time Rules, SA - Accuracy
Meas Setup, Average/Hold Number, 20, Enter
Trace/Detector, Trace Average
Single

7. Perform the following steps for each row listed in [Table 4-1.](#):
 - a. Set the synthesized sweeper amplitude to the value listed in the Nominal Source Amplitude column in [Table 4-1.](#)
 - b. Set the Step Attenuator as indicated in the Step Attenuator column in [Table 4-1.](#)
 - c. Set the Span as listed in the Span row of the table.
 - d. Record the source amplitude, as measured by the power meter, in the Power Meter Amplitude column of [Table 4-1.](#)
 - e. On the signal analyzer, press **Restart**.
 - f. Wait for the signal analyzer to finish averaging.
 - g. Press **Peak Search**.
 - h. Record the signal amplitude, as measured by the analyzer in the Measured Amplitude column of [Table 4-1.](#)

Amplitude Accuracy at 50 MHz
Procedure

- i. Calculate the signal amplitude accuracy error using the following equation, and record the results under the Amplitude Accuracy Error column:

$$\text{Amplitude Accuracy Error} = \text{Meas_amp} + \text{Step Attenuator} - \text{Power_meter}$$

Table 4-1. Amplitude Accuracy Results

Nominal Source Amplitude (dBm)	Step Atten (dB)	Span (MHz)	Measured Amplitude Meas_amp (dBm)	Power Meter Amplitude Power_meter (dBm)	Amplitude Accuracy Error (dB)	Test Limit (dB)
-4	10	2				±1.20 dB
-9	10	1				±1.20 dB
-14	10	0.5				±1.20 dB
-4	20	0.1				±1.20 dB
-14	20	0.1				±1.20 dB
-4	30	0.1				±1.20 dB
-14	30	0.1				±1.20 dB

Testing Preamp Option (P03)

Instruments containing Option P03 must have the preamp function turned on and tested.

Procedure

1. On the analyzer, press **AMPLTD Y Scale, More, Internal Preamp, Low Band**.
2. Connect the Low Power Sensor to the Power Meter, then zero and calibrate the meter.
3. Connect the equipment as shown in [Figure 4-1. on page 20](#), using a 30 dB Pad between the adaptor and the signal analyzer input.
4. Set the synthesized sweeper amplitude to the value listed in the Nominal Source Amplitude column in [Table 4-2.](#)
5. Set the signal analyzer input attenuation to 0 dB.
6. Set the Span as listed in [Table 4-2.](#)
7. Record the source amplitude, as measured by the power meter, in the Power Meter Amplitude column of [Table 4-2.](#)
8. On the signal analyzer, press **Restart**.
9. Wait for the analyzer to finish averaging.
10. Press **Peak Search**.
11. Record the signal amplitude as measured by the analyzer in the measured amplitude column of [Table 4-2.](#)
12. Calculate the signal amplitude accuracy using the following equation:

$$\text{Amplitude Accuracy Error} = \text{Meas_amp} + 30 \text{ dB} - \text{Power_meter}$$
13. Record the results under the Amplitude Accuracy Error column of [Table 4-2.](#)

Table 4-2. Amplitude Accuracy Results (Option P03)

Nominal Source Amplitude (dBm)	Low-band Preamp	Res BW (kHz)	Span (kHz)	Measured Amplitude Meas_amp (dBm)	Power Meter Amplitude Power_meter (dBm)	Amplitude Accuracy Error (dB)	Test Limit (dB)
-13	ON	1	106				±1.20 dB

Amplitude Accuracy at 50 MHz
Testing Preamp Option (P03)

5 Frequency Response (Flatness)

Test Limits

Frequency Range	Limit Relative to 50 MHz
9 kHz to 3.6 GHz	±1.7 dB
> 3.6 GHz to 7.0 GHz	±3.0 dB
> 7.0 GHz to 13.6 GHz	±3.5 dB
> 13.6 GHz to 26.5 GHz	±4.2 dB

The frequency response test measures the signal analyzer's amplitude error as a function of the tuned frequency. Measurements are made ranging from 50 MHz to the maximum frequency range of your analyzer. The signal source amplitude is measured with a power meter to eliminate error due to source flatness. The measured value is normalized to 50 MHz.

Item	Critical Specifications (for this test)	Recommended Agilent Model
Adapter, Type N(m) to 3.5 mm(m)	<i>Frequency:</i> 10 MHz to 18 GHz <i>VSWR:</i> < 1.1:1	1250-1743
Adapter, 3.5 mm(f) to 3.5 mm(f)	<i>Frequency:</i> 10 MHz to 26.5 GHz <i>VSWR:</i> < 1.1:1	83059B
Cable, 3.5 mm, 1 meter	<i>Frequency:</i> 10 MHz to 26.5 GHz <i>VSWR:</i> < 1.4:1	11500E
Cables, BNC 120 cm	<i>Frequency:</i> 10 MHz	10503A
Power Meter	Compatible with power sensor	E4418B
Power Sensor	<i>Frequency Range:</i> 50 MHz to 26.5 GHz	8485A
Power Splitter	<i>Frequency Range:</i> 50 MHz to 26.5 GHz <i>Tracking between ports:</i> < 0.25 dB	11667B
Synthesized Sweeper	<i>Frequency Range:</i> 50 MHz to 26 GHz	PSG

Figure 5-1 Frequency Response Test Setup

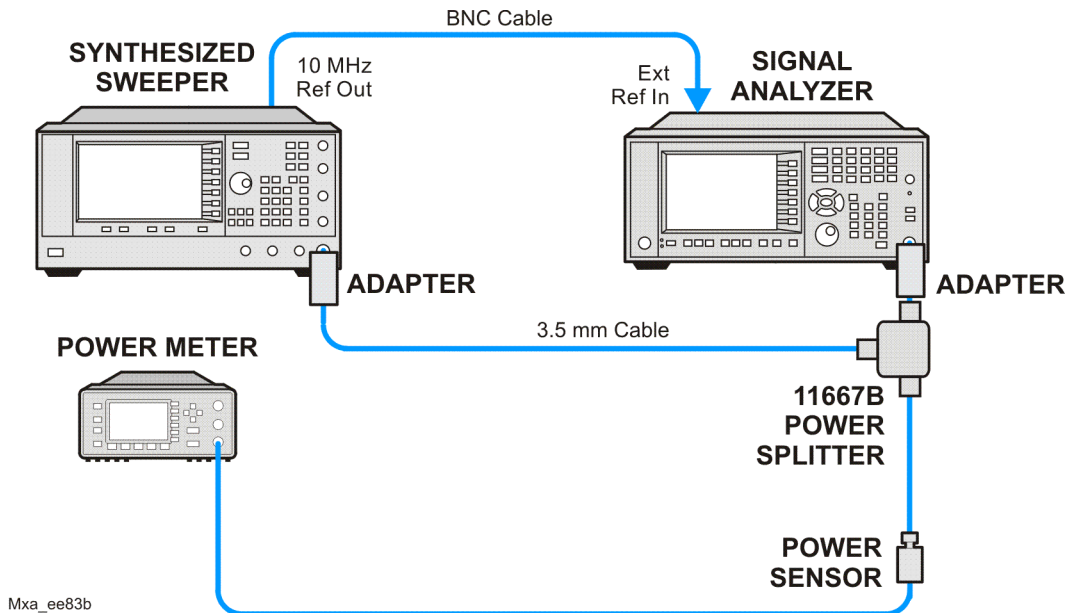

Frequency Response (Flatness)

Procedure

1. Zero and calibrate the power meter and power sensor as described in the power meter operation manual.
2. Configure the equipment as shown in [Figure 5-1](#).

NOTE Connect the power splitter to the signal analyzer input using the appropriate adapter. Do not use a cable.

3. Assure the signal analyzer's built-in auto alignment has been performed within the last 24 hours.
4. Press **Mode, Spectrum Analyzer, Mode Preset** on the signal analyzer, and press **Preset** on the synthesized sweeper.
5. Set up the synthesized sweeper by pressing:
 - CW, 50, MHz**
 - Power level, -4, dBm**
6. Set up the signal analyzer by pressing:
 - Input/Output, More, Freq Ref In, External**
 - FREQ Channel, Center Freq, 50, MHz**
 - SPAN X Scale, Span, 50, kHz**
 - AMPTD Y Scale, Ref Level, 0, dBm**
7. Adjust the synthesized sweeper output power for a power meter reading of $-10 \text{ dBm} \pm 0.1 \text{ dB}$.
8. On the signal analyzer, press **Single**.
9. Press the **Peak Search** key on the signal analyzer to position the marker on the peak of the signal.
10. Refer to [Table 5-1, "Frequency Response \(Flatness\) Results."](#) Enter the amplitude of the signal displayed on the signal analyzer into the Meas_{Amp} column of [Table 5-1](#).
11. Enter the power meter reading into the $\text{Power}_{\text{Meter}}$ column of [Table 5-1](#).
12. Tune the synthesized sweeper and signal analyzer to the next frequency listed in [Table 5-1](#).
13. Enter the power sensor calibration factor into the power meter.
14. For frequencies 3.6 GHz and above, press **AMPTD Y Scale**, then **Presel Center** to center the preselector filter for an optimum amplitude measurement.
15. Repeat [step 7](#) through [step 14](#) and complete the remainder of [Table 5-1](#) for the frequency range of your analyzer.
16. Compute the measurement error ($\text{Meas}_{\text{Error}} = \text{Meas}_{\text{Amp}} - \text{Power}_{\text{Meter}}$).

Frequency Response (Flatness)
 Procedure

17. Compute the flatness error normalized to 50 MHz:

$$(\text{Meas}_{\text{Error}} - \text{Meas}_{\text{Error}} @ 50 \text{ MHz})$$

18. Enter the computed flatness error value into the Flat_{Norm} column of Table 5-1.

19. Compare the value of Flat_{Norm} to the test limit.

Table 5-1 Frequency Response (Flatness) Results

Center Frequency	Analyzer Amplitude Meas _{amp}	Power Meter Measurement Power _{meter}	Meas Error Meas _{error}	Flatness Normalized to 50 MHz Flat _{Norm}	Flatness Error Test Limits (dB)
50 MHz				0	Ref
1 GHz					±1.7 dB
2 GHz					±1.7 dB
3 GHz					±1.7 dB
3.5 GHz					±1.7 dB
4 GHz					±3.0 dB
6 GHz					±3.0 dB
8 GHz					±3.5 dB
9 GHz					±3.5 dB
11 GHz					±3.5 dB
13 GHz					±3.5 dB
14 GHz					±4.2 dB
17 GHz					±4.2 dB
20 GHz					±4.2 dB
23 GHz					±4.2 dB
26 GHz					±4.2 dB

6 Frequency Response (Flatness), Preamp On

Test Limits

Frequency Range	Limit Relative to 50 MHz
100 kHz to 3.6 GHz	±2.2 dB

The frequency response test, with preamplifier on, measures the signal analyzer's amplitude error as a function of the tuned frequency. Measurements are made ranging from 50 MHz to the maximum frequency range of the preamp. The signal source amplitude is measured with a power meter to eliminate error due to source flatness. The measured value is normalized to 50 MHz.

Item	Critical Specifications (for this test)	Recommended Agilent Model
Adapter, Type N(m) to 3.5 mm(m)	<i>Frequency: 10 MHz to 18 GHz</i> <i>VSWR: < 1.1:1</i>	1250-1743
Adapter, 3.5 mm(f) to 3.5 mm(f)	<i>Frequency: 10 MHz to 26.5 GHz</i> <i>VSWR: < 1.1:1</i>	83059B
Cable, 3.5 mm, 1 meter	<i>Frequency: 10 MHz to 26.5 GHz</i> <i>VSWR: < 1.4:1</i>	11500E
Cables, BNC 120 cm	<i>Frequency: 10 MHz</i>	10503A
Power Meter	Compatible with power sensor	E4418B
Attenuator, 30 dB Fixed	<i>Frequency: 50 MHz</i> <i>Accuracy: ±0.05 dB</i>	11708A
Power Sensor	<i>Frequency Range: 50 MHz to 3.6 GHz</i> <i>Amplitude Range: -65 dBm to -55 dBm</i>	8481D
Power Splitter	<i>Frequency Range: 50 MHz to 26.5 GHz</i> <i>Tracking between ports: < 0.25 dB</i>	11667B
Synthesized Sweeper	<i>Frequency Range: 50 MHz to 26.5 GHz</i>	PSG

Figure 6-1 Frequency Response Test Setup

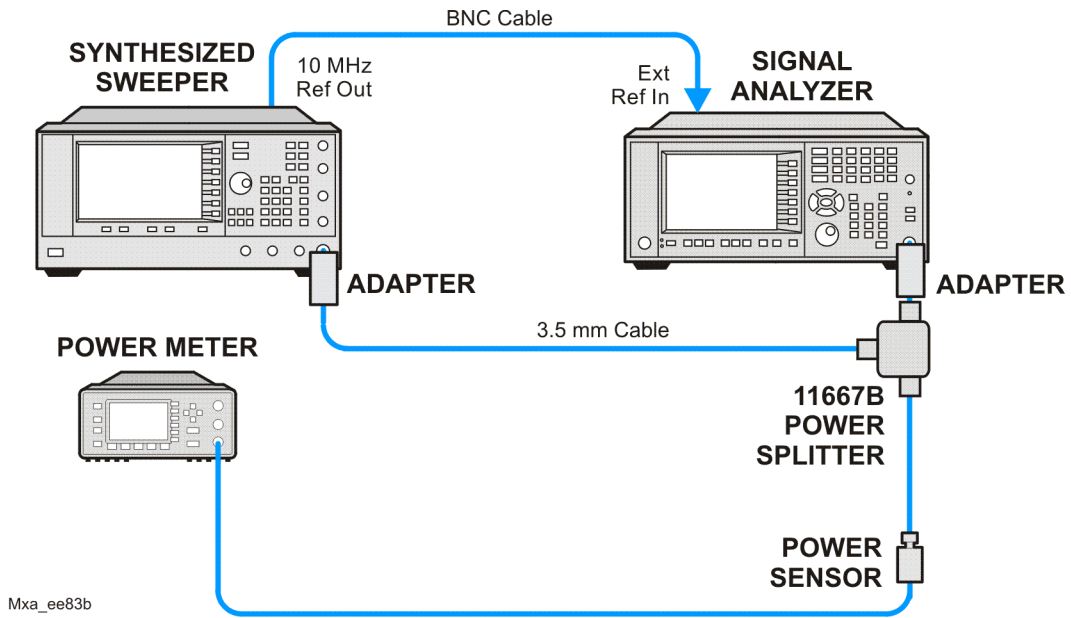

Procedure

1. Zero and calibrate the power meter and power sensor as described in the power meter operation manual.
2. Configure the equipment as shown in [Figure 6-1](#).

NOTE Connect the power splitter to the signal analyzer input using the appropriate adapter. Do not use a cable.

3. Assure the signal analyzer’s built-in auto alignment has been performed within the last 24 hours.
4. Press **Mode, Spectrum Analyzer, Mode Preset** on the signal analyzer, and press **Preset** on the synthesized sweeper.
5. Set up the synthesized sweeper by pressing:
 - CW, 50, MHz**
 - Power level, -54, dBm**
6. Set up the signal analyzer by pressing:
 - Input/Output, More, Freq Ref In, External**
 - FREQ Channel, Center Freq, 50, MHz**
 - SPAN X Scale, Span, 50, kHz**
 - AMPTD Y Scale, More, Internal Preamp, “Low Band”**
 - AMPTD Y Scale, Attenuation, Mech Atten, 0, dB**
 - AMPTD Y Scale, Ref Level, -55, dBm**
7. Adjust the synthesized sweeper output power for a power meter reading of -60 dBm ± 0.1 dB.
8. On the signal analyzer, press **Single**.
9. Press the **Peak Search** key on the signal analyzer to position the marker on the peak of the signal.
10. Refer to [Table 6-1, “Frequency Response \(Flatness\) Results.”](#) Enter the amplitude of the signal displayed on the signal analyzer into the Meas_{Amp} column of [Table 6-1](#).
11. Enter the power meter reading into the Power_{Meter} column of [Table 6-1](#).
12. Tune the synthesized sweeper and signal analyzer to the next frequency listed in [Table 6-1](#).
13. Enter the power sensor calibration factor into the power meter.
14. Repeat [step 7](#) through [step 13](#) and complete the remainder of [Table 6-1](#) for the frequency range of your preamp.
15. Compute the measurement error ($\text{Meas}_{\text{Error}} = \text{Meas}_{\text{Amp}} - \text{Power}_{\text{Meter}}$).

Frequency Response (Flatness), Preamp On
Procedure

16. Compute the flatness error normalized to 50 MHz:
 $(\text{Meas}_{\text{Error}} - \text{Meas}_{\text{Error}} @ 50 \text{ MHz})$

17. Enter the computed flatness error value into the Flat_{Norm} column of [Table 6-1](#).

18. Compare the value of Flat_{Norm} to the test limit.

Table 6-1 Frequency Response (Flatness) Results

Center Frequency	Analyzer Amplitude Meas _{amp}	Power Meter Measurement Power _{meter}	Meas Error Meas _{error}	Flatness Normalized to 50 MHz Flat _{Norm}	Flatness Error Test Limits (dB)
50 MHz				0	Ref
1 GHz					±2.2 dB
2 GHz					±2.2 dB
3 GHz					±2.2 dB
3.5 GHz					±2.2 dB

7 Scale Fidelity

Test Limits

The scale fidelity error will be $\leq \pm 1.0$ dB with ≤ -10 dBm at the mixer.

This test checks the scale fidelity of the instrument by maintaining a constant reference level and measuring signals of different amplitudes over most of the display range. This test sets the input attenuator to 10 dB and the Reference Level to 0 dBm. The external attenuator is set to 0 dB, and the amplitude of the source is adjusted to set the displayed signal at the reference level.

The instrument's internal marker is used to measure the reference amplitude. The Marker Delta function is activated and the RF input is reduced using the external precision step attenuator. Signal input levels from 0 dBm to -50 dBm are measured.

Item	Critical Specifications (for this test)	Recommended Agilent Model
Adapter, Type-N(m), to 3.5 mm(f)	Frequency: 10 MHz to 18 GHz VSWR: < 1.1:1	1250-1745
Adapter, 3.5 mm(f) to 3.5 mm(f)	Frequency: 10 MHz to 26.5 GHz VSWR: < 1.1:1	83059B
Attenuator, 10 dB Step	Range: 0-50 dB Frequency: 50 MHz Accuracy: ± 0.25 dB	8495A
Attenuator, 10 dB fixed (2 required)	Frequency: 50 MHz VSWR: < 1.2:1	8493C, option 010
Cable, 3.5 mm, 1 meter (2 required)	Frequency: 10 MHz to 26.5 GHz VSWR: < 1.4:1	11500E
Cable, BNC 120 cm	Frequency: 10 MHz	10503A
Synthesized Sweeper	Output Level Accuracy: 0 to -15 dBm: ± 1.0 dB	PSG

Figure 7-1. Scale Fidelity Setup

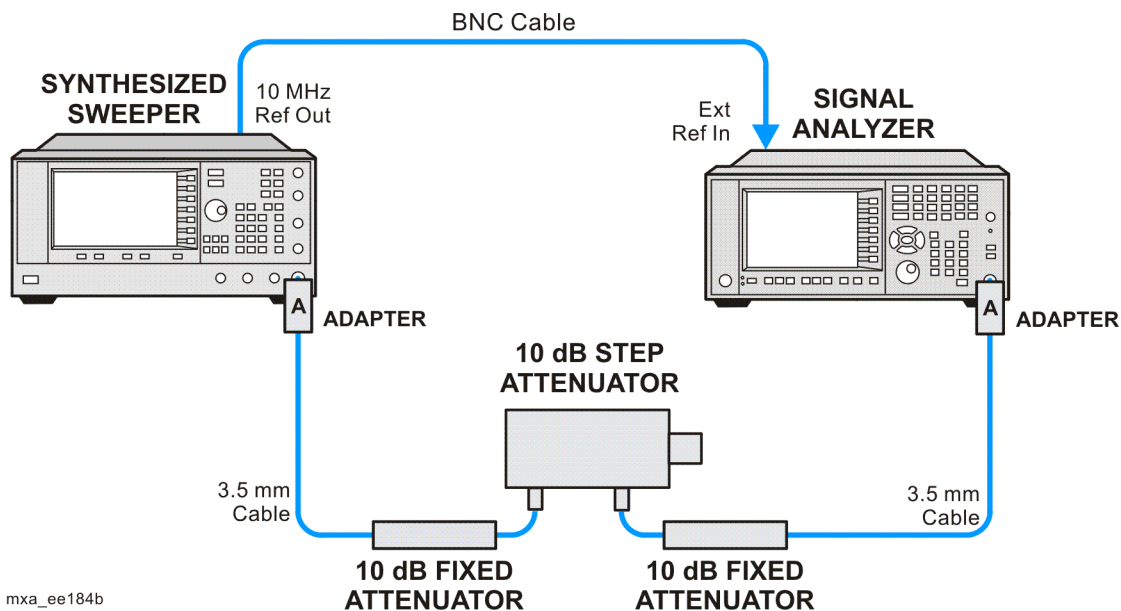

NOTE Averaging is used for all measurements to improve repeatability and reduce measurement uncertainty.

Procedure

1. Configure the equipment as shown in [Figure 7-1.](#)
2. Preset the Source and press **Mode, Spectrum Analyzer, Mode Preset** on the analyzer.
3. Set up the synthesized sweeper by pressing:
 - Frequency, 50, MHz**
 - Amplitude, +5, dBm**
 - RF On/Off, On**
4. Set up the signal analyzer by pressing:
 - Input/Output, More, Freq Ref In, External**
 - FREQ Channel, Center Freq, 50, MHz**
 - SPAN X Scale, Span, 1, MHz**
 - AMPTD Y Scale, Ref Level, 0, dBm**
 - Meas Setup, Average/Hold Number, 10, Enter**
 - Trace/Detector, Trace Average**
 - Peak Search**
5. Set the external 10 dB step attenuator to 0 dB.
6. Adjust the amplitude on the signal source until the marker amplitude on the analyzer reads $-15 \text{ dBm} \pm 0.2 \text{ dB}$.
7. On the analyzer, press the **Single, Restart** to trigger a 10 sweep average.
8. On the analyzer, activate the Marker Delta function by pressing **Peak Search, Marker Delta**.
9. Perform the following steps for each attenuator setting listed in the table below:
 - a. Select the next External attenuator setting.
 - b. Press the **Restart** key to trigger a 10 sweep average.
 - c. Enter the delta marker value into [Table 7-1](#).
 - d. Check delta marker reading against the test limits.

Table 7-1 Scale Fidelity Results

External Attenuator Setting	Minimum (dB)	Marker Delta Value (dB)	Maximum (dB)
0	N/A	Reference	N/A
10	-11.0		-9.0
20	-21.0		-19.0
30	-31.0		-29.0
40	-41.0		-39.0
50	-51.0		-49.0

A

Agilent Technologies URL, [2](#)
amplitude accuracy test, [19](#)
 option 1DS, [23](#)
amplitude linearity test, [33](#)

D

DANL test, [13](#)
displayed average noise level. See
 DANL, [13](#)

E

equipment
 functional tests, [9](#)
 warm-up time, [8](#)

F

frequency readout accuracy test,
 [17](#)
frequency response (flatness) test,
 [25](#)
 preamp on, [29](#)
functional testing
 performance verification, [6](#)
functional tests
 before performing, [8](#)
 equipment list, [9](#)
 introduction, [5](#)
 vs performance verification
 tests, [6](#)
 warm-up time, [8](#)
 See also individual functional
 tests, [5](#)

P

performance verification tests vs
 functional tests, [6](#)

T

tests. See functional tests

U

URL (Agilent Technologies), [2](#)

Index
